



Perspective
Sliding Folding Glass Walls

www.creatif.org.uk

02_Perspective

The development of Perspective Wall has acknowledged previous architectural challenges and created new options for space division.

Our team have created a high aesthetic system with concealed hinges and a discreet aluminium frame. Available in a wide range of surface finish options and panel configurations. The Perspective Wall is a quick, easy to operate solution that achieves good levels of acoustic performance.

Contents:

Page 05	Profile
Page 06	Technical Information
Page 07	Stacking Configurations
Page 08	Swatches
Page 09	Contact







05_Profile

- A. Head Profile
- B. Floor Profile
- C. Floor Track

A

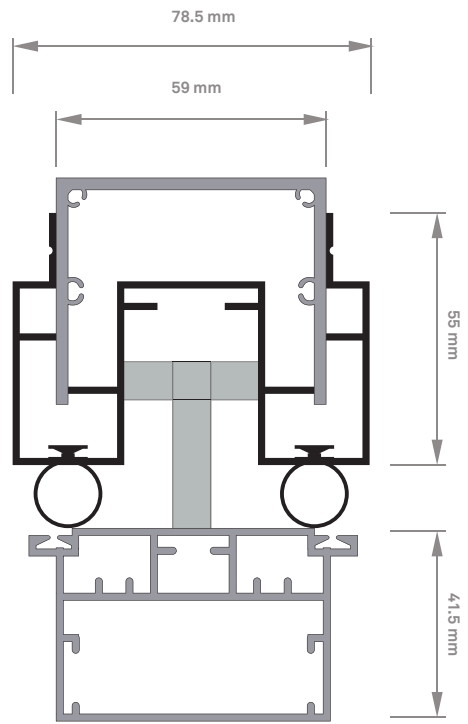

B

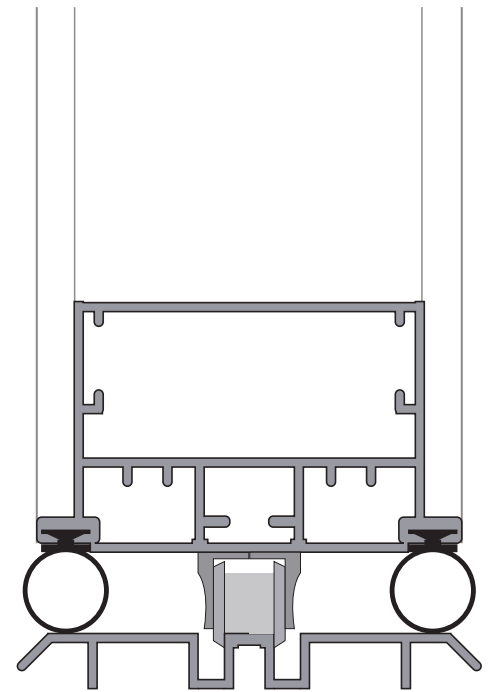

C

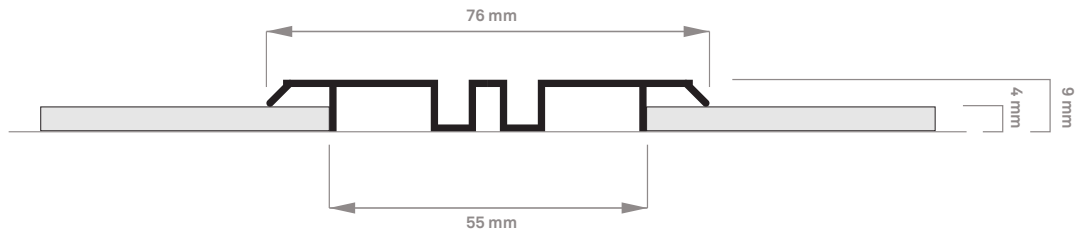

06_Technical Information

Please contact us for further information.

	Perspective
Panel Construction	MFC / MDF / Glazed
Connections	Aluminum Profiles
Operations	Manual
Acoustic Rating	42-43 dB (RW)
Thickness	70mm
Weight	25-42 KG / m ²
Max Panel Height	4,000mm
Max Panel Width	540-900mm
Max Opening Width	Adjustable (mm)

07_Stacking

Config A; Single point, end fold

Config B; Single-point, Centre stack

Config C; Twin-point, Offset Stack

Config D; Twin-point, Corner Track

Config E; Twin-point, Split Offset Track

For details on other stacking configuration, please contact us: sales@creatif.org.uk

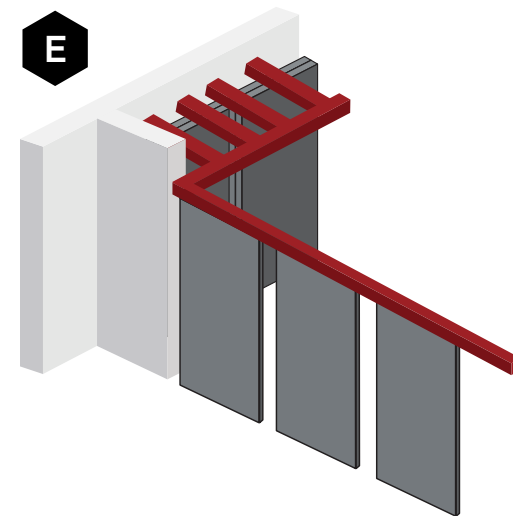
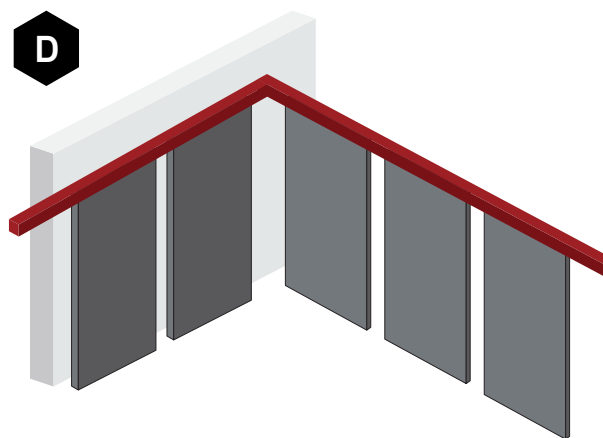
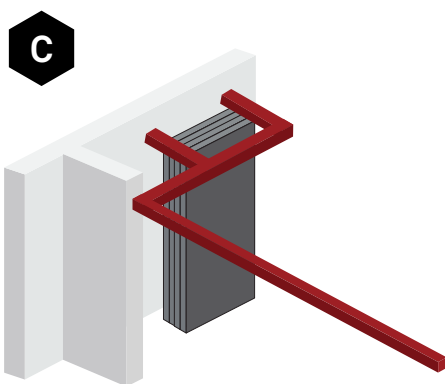
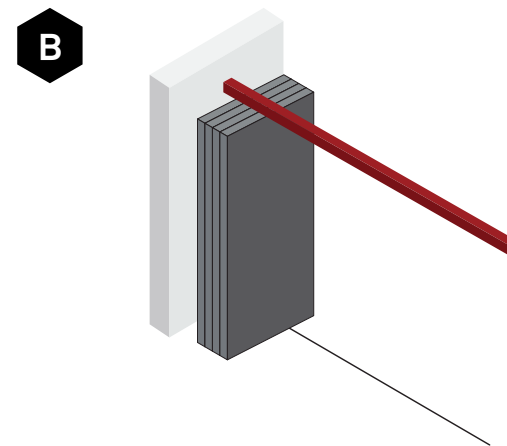
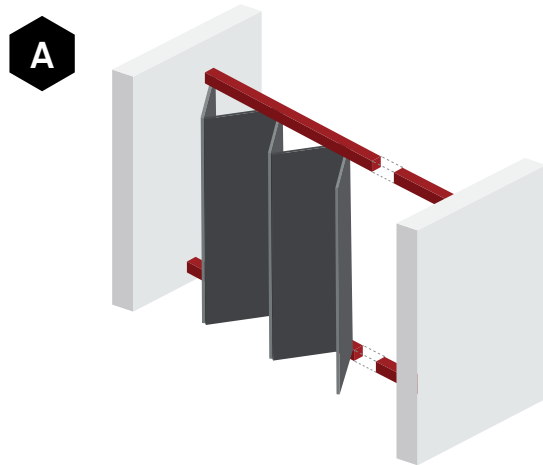

08_Finish Options

For a sample or details regarding bespoke finishes, please get in touch with Creatif:
sales@creatif.org.uk



Reysipur
B100

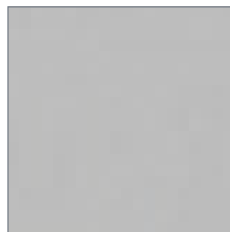

Reysipur
G044

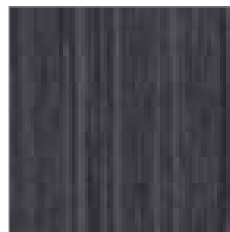

Reysipur
B101

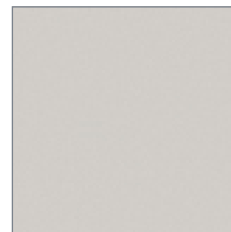

Reysipur
B116

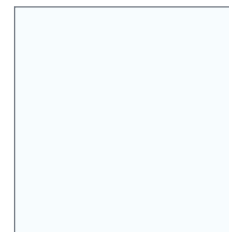

Reysipur
B188

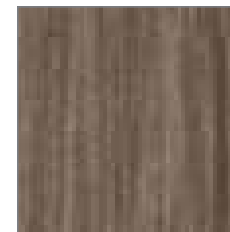

Reysipur
C132

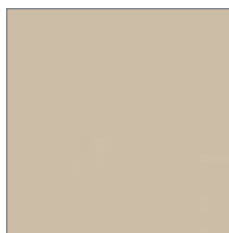

Reysipur
F054

09_Contact

Details

T: +44 (0) 113 270 1239

F: +44 (0) 113 239 1672

E: info@creatif.org.uk

Head Office

Unit 2 National Road
Business Park,
National Road,
Leeds LS10 1TE

Visit our website to find out more...



www.creatif.org.uk