



**creatif**

**Clarity**  
Super-Slim Glass Moving Wall

[www.creatif.org.uk](http://www.creatif.org.uk)

## 02\_Clarity

For transparency and quality, nothing matches Clarity from Creatif. Precision engineered components work together as an integral whole to create room dividers that are as subtle as they are robust.

With Clarity you can create an infinite variety of configurations including curved track runs and even curved glass. Bespoke stacking configurations enable panels to stack totally out of sight when in the open position – a feature ideal for high-end retail environments.

Unique product features include smooth curved end caps for enhanced aesthetics, a foot-operated floor-bolt system.

## Contents:

<b>Page 04</b>	Technical Details
<b>Page 05</b>	Stacking Configuration
<b>Page 06</b>	Technical Information
<b>Page 07</b>	Swatches
<b>Page 08</b>	Available Panels Elevations
<b>Page 09</b>	Contact



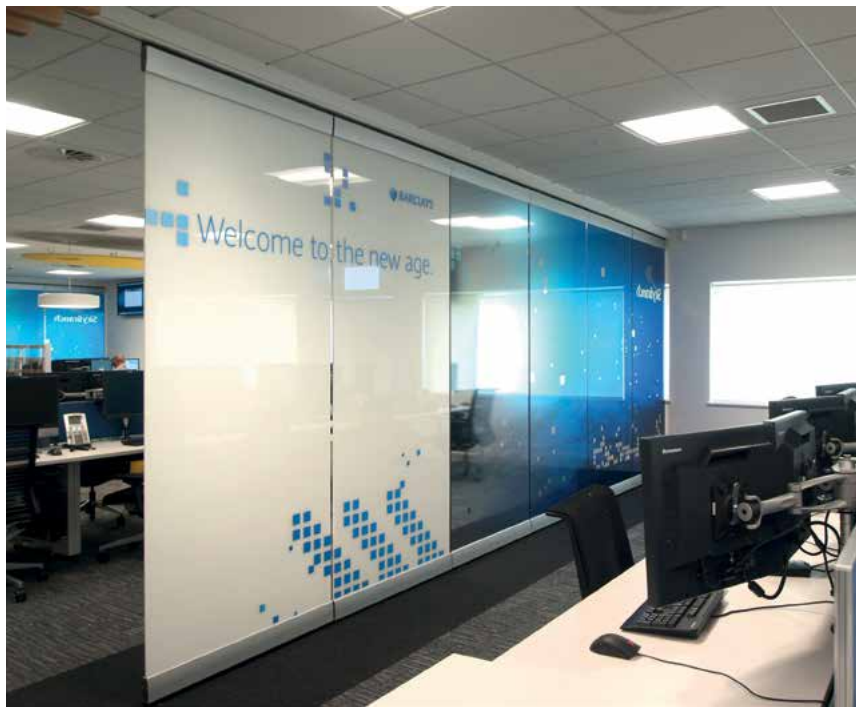
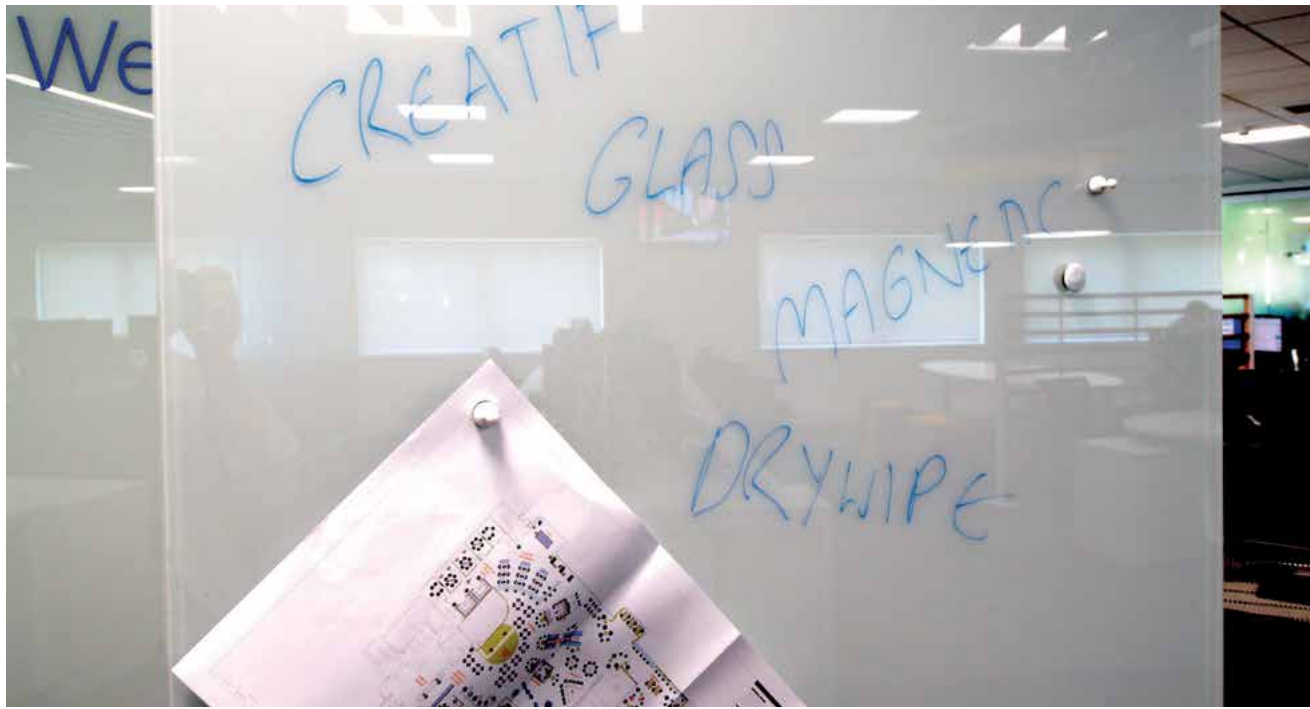

# 04\_Technical Details

- 1. L - Angle
- 2. Standard Panel
- 3. U - Channel
- 4. Twin Point
- 5. Twin Point with Pelmet
- 6. Bottom Profile
- 7. Auto Foot Bolt
- 8. Pin Joint
- 9. Face Foot Bolt

1

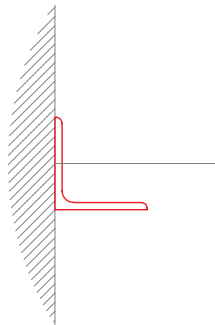

2

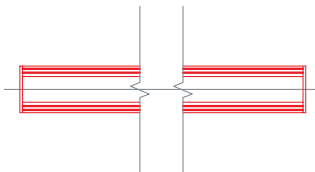

3

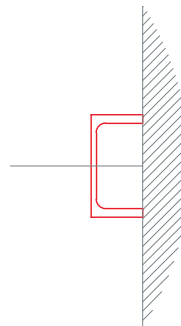

4

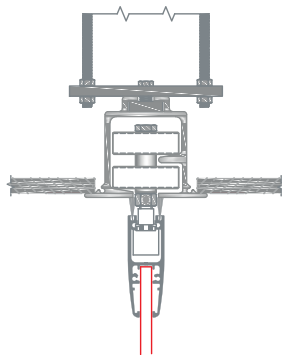

5

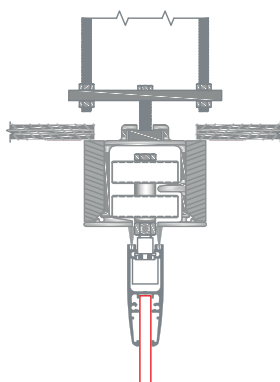

6

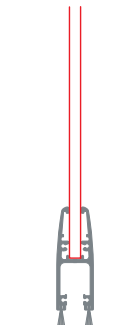

7

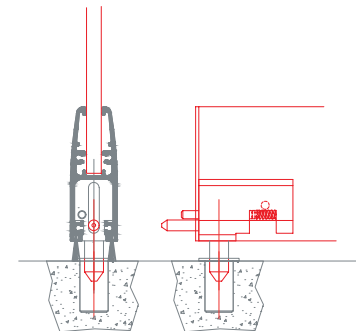

8

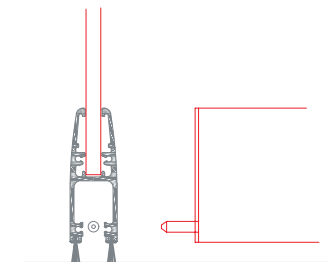

9

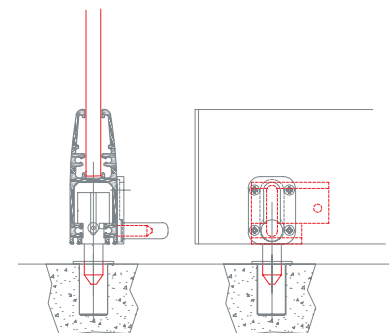

## 05\_Stacking Configuration

Config A  
Twin-point,  
H-park

Config B  
Twin-point,  
Offset Stack

Config C  
Twin-point,  
Linear Stack

Config D  
Twin-point,  
H-park Split

Config E  
Twin-point,  
Split Offset Track

Please note:  
Panel thickness will  
vary depending on  
system type.

Other stacking options  
are available on  
request.

Please contact Creatif  
for further details.

A

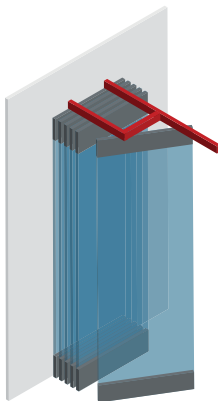

B

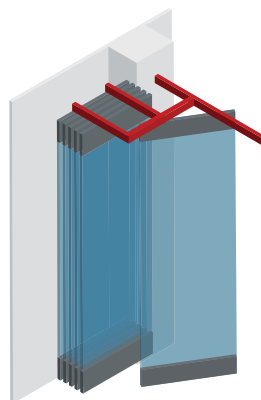

C

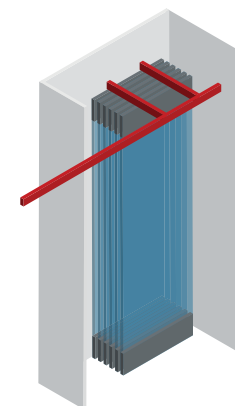

D

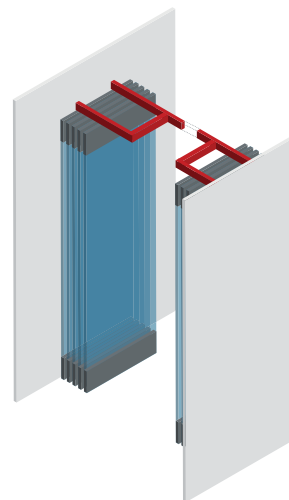

E

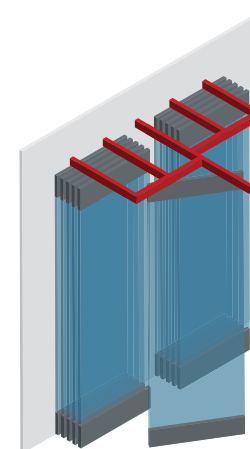

## 06\_Technical Information

Glass is expected to bow up to 3mm per linear metre, which is within the industry standards for bowing tolerances. Creatif will not be held liable for any bow within this parameter.

	CLARITY
Glass thickness	10mm or 12mm
Profile thickness	35mm
Weight KG/M <sup>2</sup>	32kg
Max. height	3000mm
Max. panel width	1220mm
Board type	Glass
Operable seal	Manual foot-operated bolt into socket
Track system	Aluminium TP
Tolerance height MM	+/- 3mm
Tolerance width MM	+/- 3mm

## 07\_Swatches

Other colours available on request. Contact Creatif: [sales@creatif.org.uk](mailto:sales@creatif.org.uk)

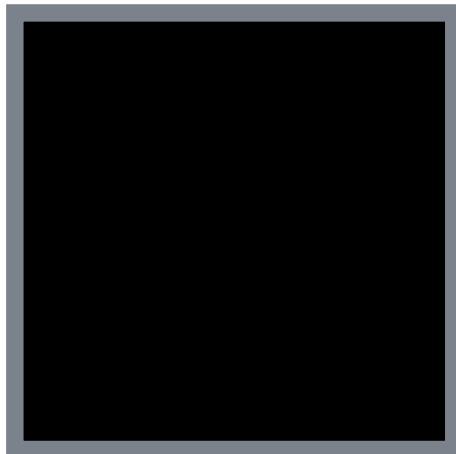

Back-painted glass



Manifestations

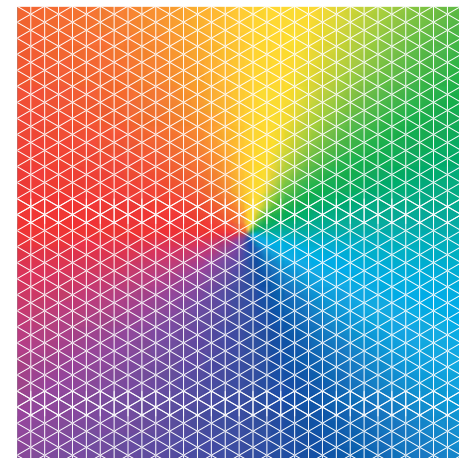

Powder-coated RAL colours for profiles and tracks

Other colours available on request

## 08\_Available Panels Elevations

If solid MFC panels are required within the same set, please refer to our Float product.

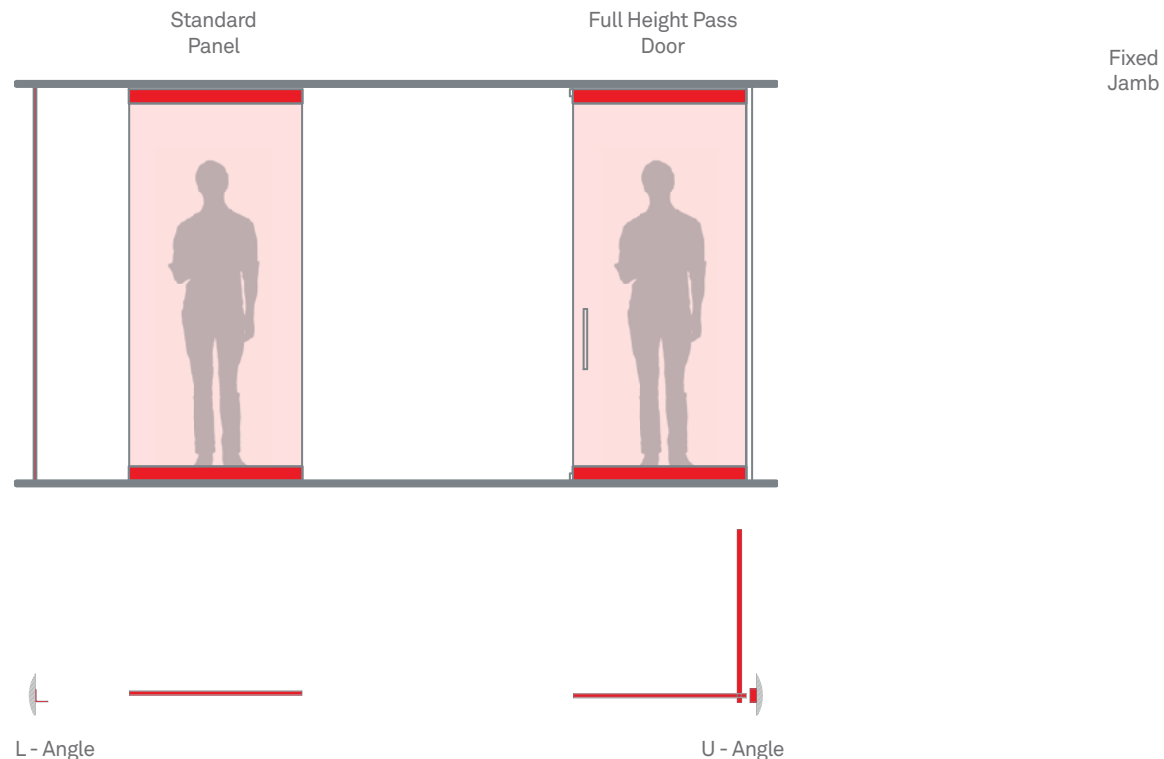

### Features and Benefits

- » Elegant space flexibility – configurable space.
- » No vertical profiles – stunning aesthetics and extensive light transfer without acoustic attenuation.
- » Slim and unobtrusive – enabling efficient use of space.
- » No floor track – unbroken floor surface.



## 09\_Contact

### Details

T: +44 (0) 113 270 1239

F: +44 (0) 113 239 1672

E: info@creatif.org.uk

### Head Office

Unit 2 National Road  
Business Park,  
National Road,  
Leeds LS10 1TE

Visit our website to find out more...



[www.creatif.org.uk](http://www.creatif.org.uk)